

DATASHEET

Product name: 2835 0.5W white



- ❖ Outline (L×W×H: 3.5mm×2.8mm×0.9mm)
- ❖ Forward current : ≤150mA
- ❖ Typical viewing angle 50% Iv: 120°
- ❖ Emitting color : white
- ❖ Lens color : yellow
- ❖ MSL: Level 3 Based on JEDEC J-STD 020
- ❖ RoHS & REACH-compliant RoHS and CE.

This is a preliminary specification intended for design purposes and subject to change without prior notice.

➤ PLEASE PAY ATTENTION TO THE MOISTURE-ABSORBING PROBLEM, AND REFER TO THE OPERATING INSTRUCTIONS FOR THE DETAILS

Model No	HI2835X05W65	
Customer Name		
Check By	Authorized By	Application Range

◆
Please return the book that stamp admitted

☆☆

Add: 79 building ,hou ting second Industrial park,Shajing town baoan district,Shenzhen ,,Guangdong ,China

TEL: 86-755-61893087 **FAX:** 86-755-861893085 **Http://** www.hico-led.com **E-mail:** info@hico-led.com

❖ Outline Dimensions

Item	Materials
Resin(Mold)	Silicone
Lens Color	Yellow
LED Diec	InGaN
Emitting Colors	White

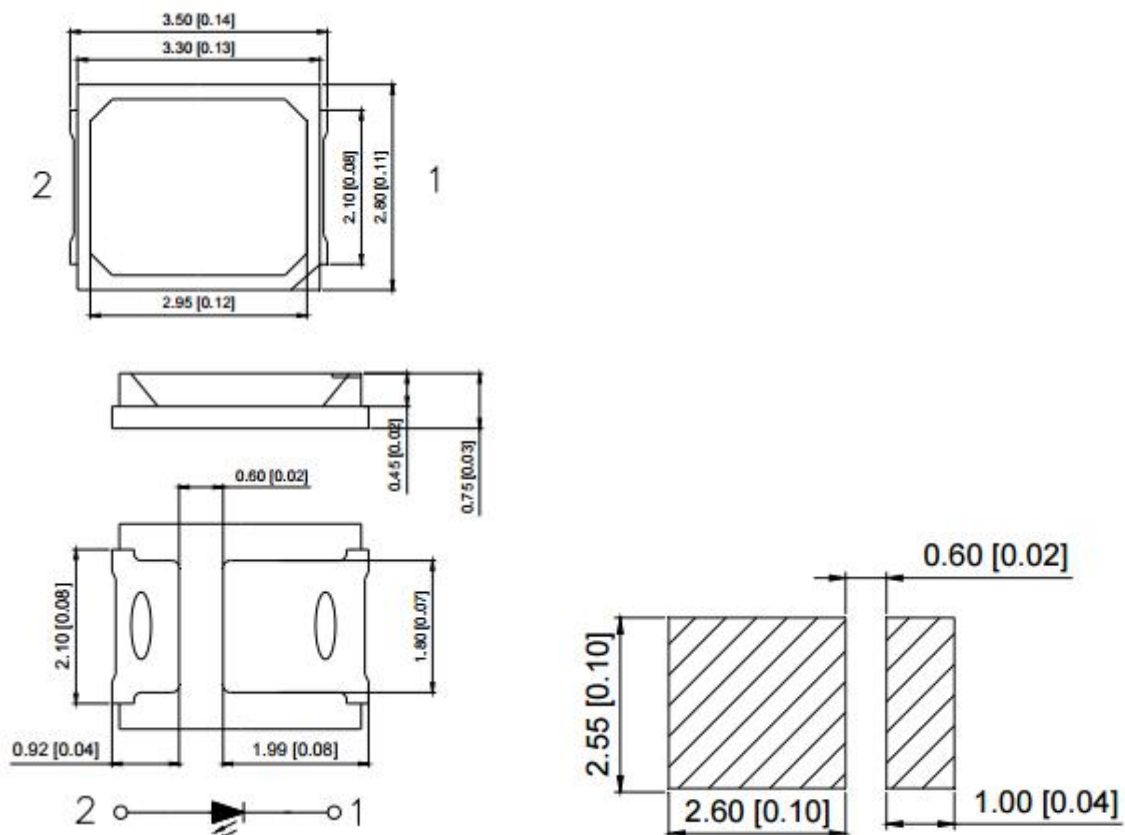

Notes:

- ❖ All dimensions are in millimeters(inh)
- ❖ Tolerance is +/-0.1mm(0.004 ") unless otherwise noted
- ❖ Specifications are subject to changes for improvement without advance notice Proprietary data, Drawings, Company confidential all rights reserved.

❖ Absolute Maximum Ratings (Ta=25°C)

Item	Symbol	Value	Unit
Power Dissipation	P _D	500	mW
DC Forward Current	I _F	150	mA
Pulsed Forward Current	I _{FP}	180	mA
Reverse Voltage	V _R	5	V
Junction Temperature	T _j	115	°C
Storage Temperature	T _{stg}	-40 ~ +100	°C
Soldering Temperature	T _{sol}	260for10sec	°C

Notes:

- ❖ * Duty 1/10, Pulse Width 0.1ms
- ❖ ▲ Please refer to the Curve of Forward Current vs. Ambient Temperature.

❖ Electrical-Optical Characteristics (Ta=25°C)

Parameter	Symbol	Value			Unit	Test condition
		Min.	Typ.	Max.		
Forward Voltage	V _f	3.0	---	3.4	V	I _f =150mA
Luminous Flux	Φ	58	60	63	lm	I _f =150mA
Color temperature	CCT	6000	6250	6500	K	I _f =150mA
Color Rendering Index	CRI	80	---	---	---	I _f =150mA
Reverse Current	I _r	---	---	10	μA	V _r =5V
Viewing angle	2θ _{1/2}	---	120	---	Deg	I _f =150mA

Notes:

- ❖ Luminous intensity (mcd) ±10%, Forward Voltage(VF) ±0.1V, Wavelength(x,y) ±1nm/±0.01
- ❖ IS standard test

Junction Temperature < 115°C

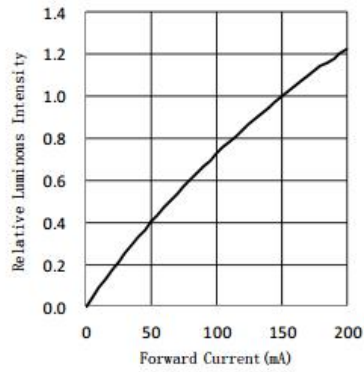
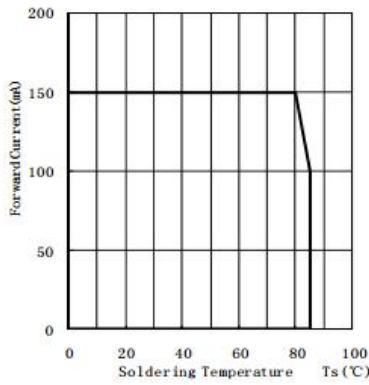

Forward Voltage VS. Forward Current
正向电压与正向电流特性曲线

Ambient Temperature VS. Relative Intensity
环境温度与相对光强特性曲线

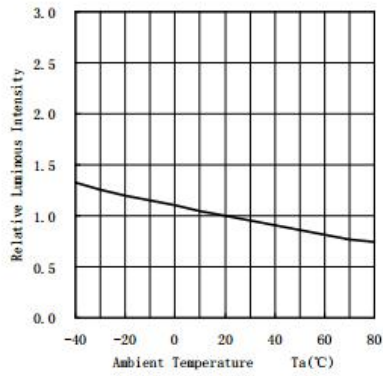
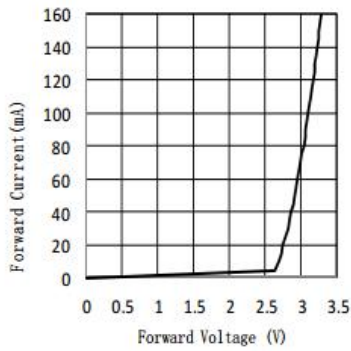

Typical optical characteristics curves 典型光学特性曲线

Relative spectral emission 相对光谱分布特性曲线

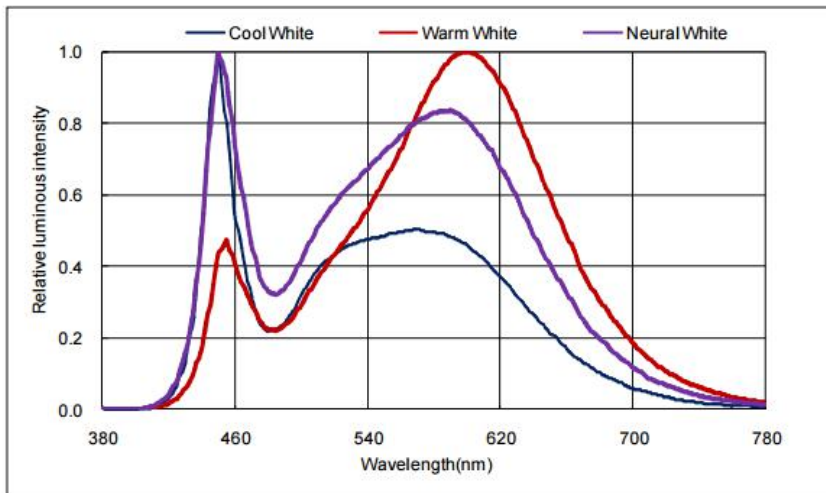

Radiation diagram 辐射图特性曲线

Recommended Soldering Conditions

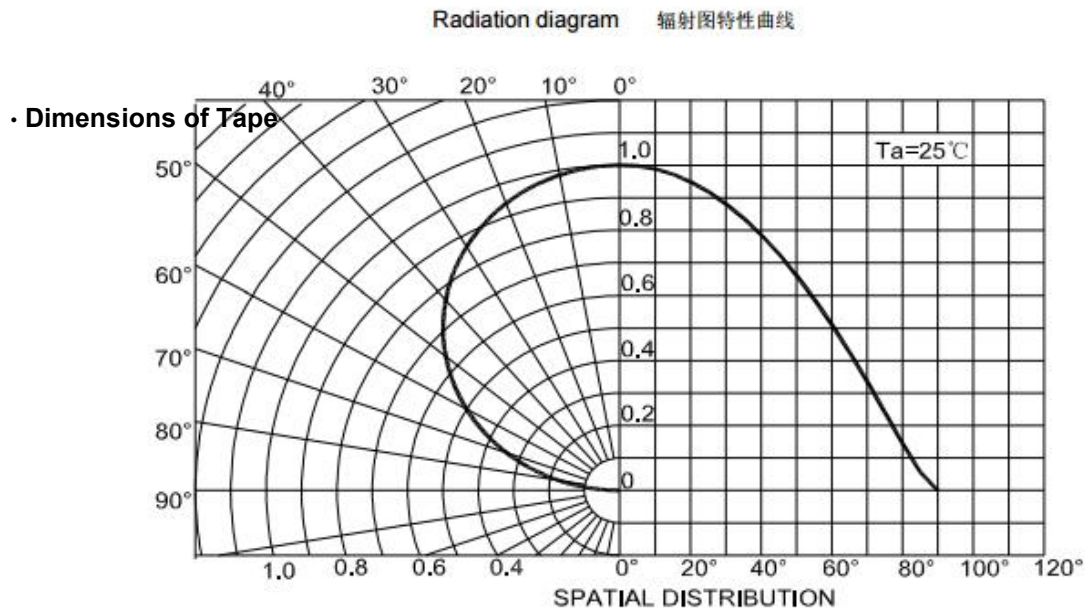

Tape and Reel Dimensions

Note: 4000 pcs/Reel

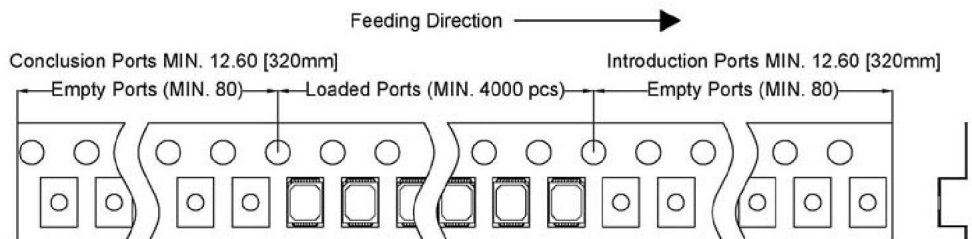
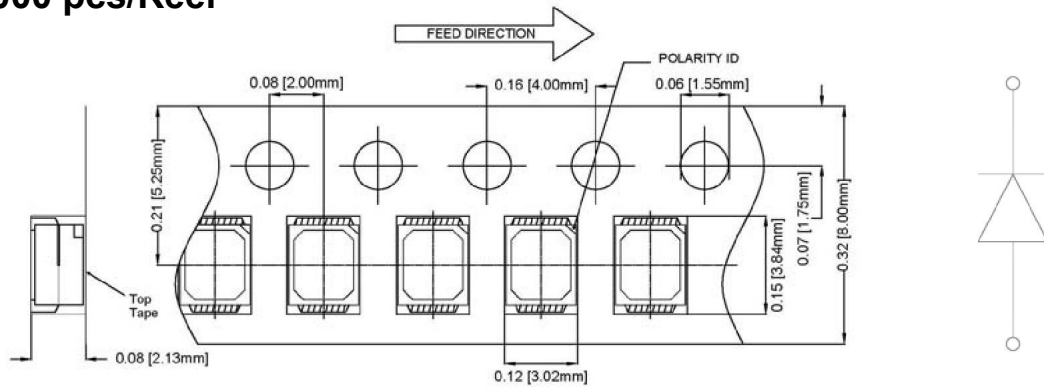

LED Usage and Handling Instructions

Dear valued clients:

Thank you for choose our LED products. LEDs are delicate semiconductor product that should be handle according to the below instructions.

A. Storage :

1. SMD LEDs should be stored in a sealed container at less than 30 °C and 90 % (RH) with silica gel desiccants to ensure their shelf life will not exceed 1 year.
2. SMD LED is a humidity sensitive product it complies with JEDEC MSL 3 or equivalent see IPC/JEDEC STD-020 for moisture-sensitivity details.

2.1 Shelf life shee

Conditions		Temperature	Humidity	Time
Storage	Before opening bag	≤30 °C	≤90%RH	Within 1 year from Delivery Date
	After opening bag	≤30 °C	≤60%RH	≤168Hrs
Baking		65+/-5 °C	≤10%	≥48Hrs

3. Absorbed moisture in LED packages can vaporize and expand during soldering, which can cause interface delamination and result in optical performance degradation. Products are packed in moisture-proof bags to minimize moisture absorption during transportation and storage. Included silica gel desiccants change from blue to Blue if moisture had penetrated bags.
4. After opening the moisture-proof bag, the LEDs should go through the soldering process within the range of the conditions stated above. Unused remaining LEDs should be stoBlue with silica gel desiccants in a hermetically sealed container, preferably the original moisture-proof bags for storage.



5. After opening the moisture-proof bag, the LEDs should go through the soldering process within the range of the conditions stated above. Unused remaining LEDs should be stored with silica gel desiccants in a hermetically sealed container, preferably the original moisture-proof bags for storage.
5. After the “Period after opening” storage time has been exceeded or silica gel desiccants are no longer blue, the products should be baked. Baking should only be done once.
6. Customer is advised to keep the LEDs in an airtight container when not in use. Exposure to a corrosive environment. May cause the plated metal parts of the product to tarnish, which could adversely affect soldering and optical characteristics. It is also recommended to return the LEDs to the original moisture proof bags and reseal.
7. After assembly and during use, silver plating can be affected by the corrosive gases emitted by components and materials in close proximity of the LEDs within an end product, and the gases entering into the product from the external atmosphere. The above should be taken into consideration when designing. Resin materials, in particular, may contain substances which can affect silver plating, such as halogen.
8. Do not use sulfur-containing materials in end of products. Some materials such as seals and adhesives may contain sulfur. The extremely corroded or contaminated plating of LEDs might cause an open circuit. Silicone rubber is recommended as a material for seals.
9. To prevent water condensation, please avoid large temperature and humidity fluctuations for the storage conditions.
10. Do not store the LEDs in a dusty environment.
11. Do not expose the LEDs to direct sunlight and/or an environment where the temperature is higher than normal room temperature.

B. Cleaning :

1. Do not use any unidentified chemical to clean LEDs, it could damage or crack the LED epoxy surface. If necessary, soak LED in isopropyl alcohol (IPA) for a time not exceeding one minute in normal temperature.
2. Ultrasonic cleaning is not recommended since it may have adverse effects on the LEDs depending on the ultrasonic power and how LED is assembled. If ultrasonic cleaning must be used, the customer is advised to make sure the LEDs will not be damaged prior to cleaning.

C. ESD (Electrostatic Discharge)

1. LED is very sensitive to ESD; please make sure during the whole usage and installation process, that no ESD exist to affect the LED. Excessive ESD could damage the LED chip and result in performance degradation.
2. LED can also be damaged by electrical surge, please make sure any driving electrical circuits are equipped with surge protection.
3. During the installation process, please make sure all the equipment and personnel are grounded properly. Make use ESD protection equipment such as anti-static gloves, anti-static wrist bands, anti-static mats, anti-static clothes, anti-static shoes, and anti-static containers.
4. When LED come into contact with low electrical resistance metallic surfaces, the ESD could damage the LED due to sudden discharge of ESD. Please make sure all surfaces that will be in contact with LED are covered with anti-static mats (Surface electrical resistance of $10^6 \sim 10^8 \Omega/\text{sq}$). LED should be placed in anti-static containers and anti-static bags.
5. All soldering irons and Test equipments should be grounded and production environment should make use of ion-blowers.

D. Installation

1. During the installation process, do not apply any pressure to the LED lens.
2. During the installation process, do not touch to the LED lens.
3. Please make sure the installation part dimension matches the dimension of the LED. Including to tolerance.

E. Handling Precautions

1. As silicon is softer and flexible, its characteristic significantly reduces thermal stress, It is more susceptible to damage by external mechanical force; As a result ,special handling precautions need to be observed during assembly using silicone encapsulated LED products ,failure to comply might leads to damage and premature failure of the led;

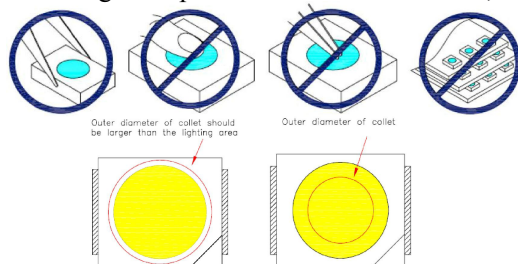

F. Directions for Use.

1. When designing a circuit, the current through each LED must not exceed the Absolute Maximum Rating. (refer to page 3)
2. Operating at a constant current per LED is recommended. In case of operating at a constant voltage, circuit B is recommended. If the LEDs are operated with constant voltage using circuit A, the current through the LEDs may vary due to the variation in Forward Voltage characteristics of the LEDs.

- 1) Serial connection

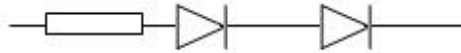

- 2) Parallel connection

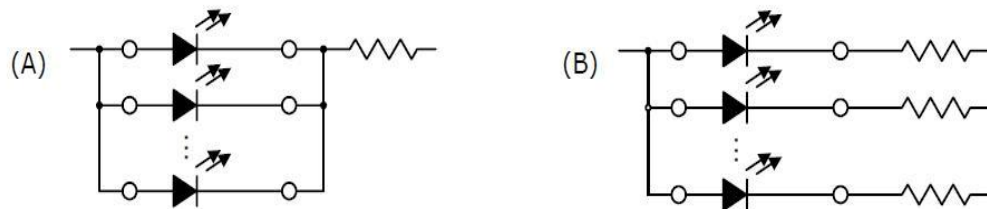

3. Sudden surge could damage the LED interior connections. Please design circuit with care so no sudden voltage surge or current surge will show when turning the circuit on or off.
4. When color or brightness uniformity is required while using multiple LEDs, the LED driver condition is critical. Our company guarantees the uniformity of the LEDs from the same bin when the driver current with same sorting current.

G. Soldering

1. Recommend soldering paste specifications:

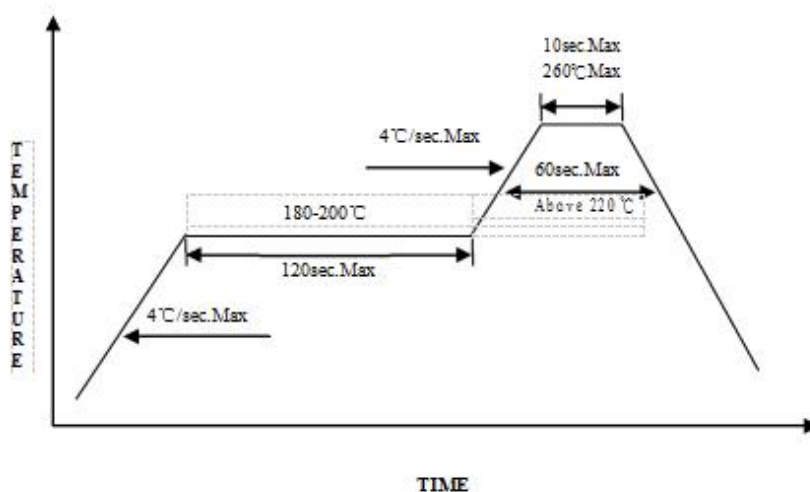

2. When reflow soldering , please solder once for less than 10 seconds at a maximum temperature of 260°C. During the soldering process, if the temperature or timing is not controlled within limits, it would cause the epoxy to deform or cause the die or wires within the LED to be damaged.
3. Do not dip the epoxy encapsulation part of LED into any soldering paste liquid and solder.
4. After soldering, do not adjust the location of the LED anymore.
5. Don't recommend using the soldering iron and wave soldering to solder.
6. When reworking that should be completed within 3 seconds under 260°C. The iron tip must not come in contact with the copper foil. Twin-head type is preferred.
7. If have to through the wave soldering machine, shall be protect the LED resin and within limit temperature / timing /times as avoid LED to be damaged

H. Eye Safety

1. Please comply with government electrical safety code while using the LEDs.
2. Do not look directly into a lit LED; it could feel uncomfortable the eyes.
3. Do not look directly into power UV LEDs; it could damage the eyes after only a few seconds. (UV LEDs are mainly used in currency validating machines and the Sterilize instruments)
4. In 2006, the International Electrical Commission (IEC) published IEC 62471:2006 photobiological safety of lamps and lamp systems, which added LEDs in its scope. On the other hand, the IEC60825-1:2007 laser safety standard removed LEDs from its scope. However, please be advised that some countries and regions have adopted standards based on the IEC laser safety standard IEC60825-1:2007, which still includes LEDs in its scope. Most of our LEDs can be classified as belonging into either the Exempt Group or Risk Group1. High-power LEDs, that emit light containing blue wavelengths, may be classified as Risk Group2.
5. Viewing a flashing light may cause eye discomfort. When incorporating the LED into your product, please be careful to avoid adverse effects on the human body caused by lighting stimulation.